

Versione FISSA con gancio

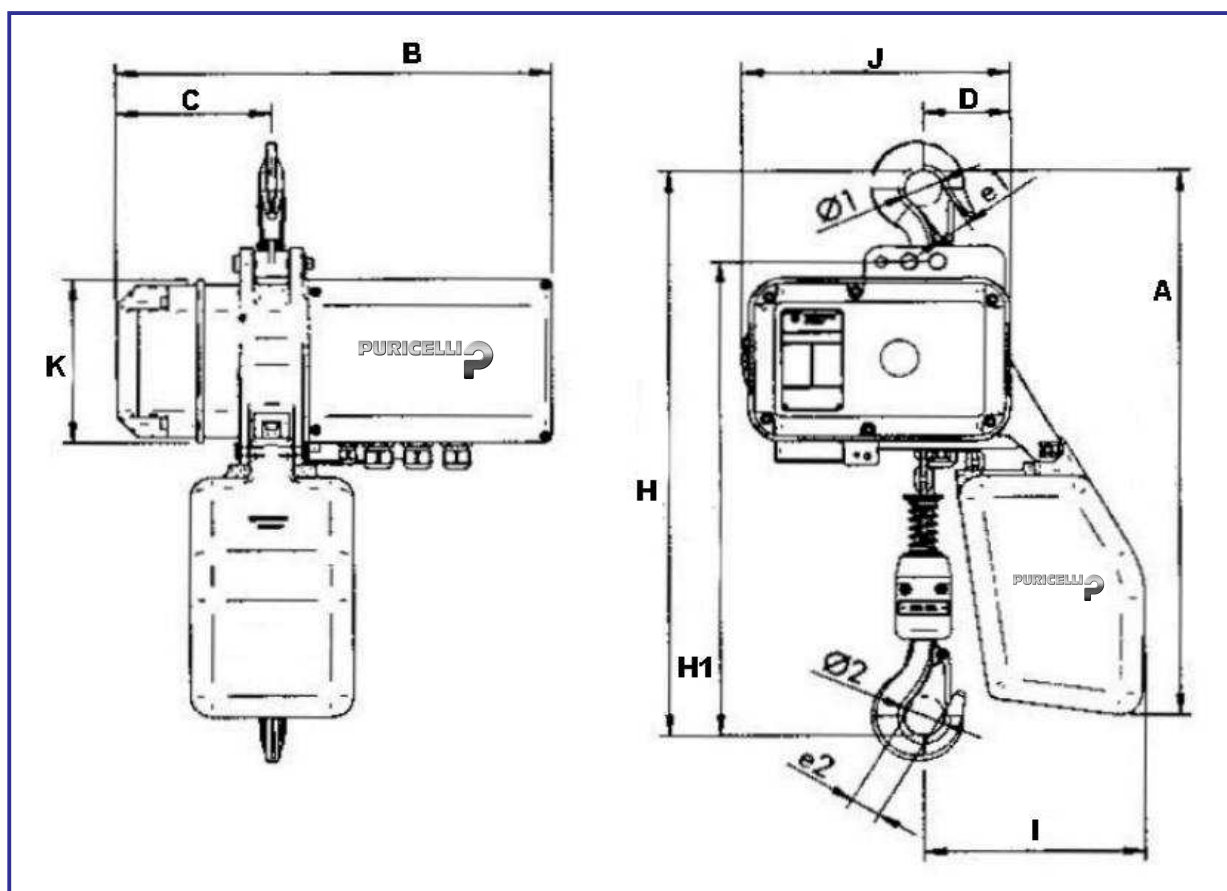

Portata S.W.L. kg	Tipo Type	A mm	B mm	C mm	D mm	H mm	I mm	J mm	K mm	1 - 2 mm	e 1-2 mm
250	EL0-208-U	511	387	138	78	451	197	239	154	28	36
250	EL0-208-D	511	387	138	78	451	197	239	154	28	36
500	EL0-506-U	511	387	138	78	451	197	239	154	28	36
500	EL0-504-D	511	387	138	103	472	222	239	154	28	36
500	EL1-508-U	509	387	138	85	449	197	266	164	28	36
500	EL1-508-D	509	409	138	85	449	197	283	164	28	36
1000	EL0-1003-U	511	387	138	103	472	222	239	154	28	36
1000	EL1-1004-U	509	387	138	95	455	206	266	164	28	36
1000	EL1-1004-D	509	409	138	110	470	222	263	164	28	36
1000	EL2-1008-U	538	396	136	105	478	206	292	184	28	36
1000	EL2-1008-D	538	438	136	105	478	206	291	184	28	36
1600	EL2-1604-U	591	396	136	139	610	240	292	184	41	53
1600	EL2-1604-D	591	438	136	139	610	240	292	184	41	53
1600	EL3-1606-U	626	485	148	135	574	259	344	216	41	53
1600	EL3-1605-D	626	563	148	181	651	305	344	216	41	53
2000	EL2-2004-U	591	396	136	139	610	240	292	184	41	53
2000	EL2-2004-D	591	438	136	139	610	240	291	184	41	53
2000	EL3-2005-U	626	485	148	135	574	259	344	216	41	53
2000	EL3-2005-D	626	563	148	135	574	259	344	216	41	53
2.500	EL3-2504-U	626	485	148	181	651	305	344	216	42	54
2.500	EL3-2503-D	626	563	148	181	651	305	344	216	42	54
3.200	EL3-3203-U	626	485	148	181	651	305	344	216	42	54
3.200	EL3-3202-D	626	563	148	181	651	305	344	216	42	54
4.000	EL3-4002-U	658	485	148	181	732	305	344	216	54	68
4.000	EL3-4002-D	658	563	148	181	732	305	344	216	54	68
5.000	EL3-5002-U	658	485	148	181	732	305	344	216	54	68